

LC223S Flow Controller

Gas or Liquid Flow Controller

aerospace
climate control
electromechanical
filtration
fluid & gas handling
hydraulics
pneumatics
process control
sealing & shielding

Customer Value Proposition:

The LC223S is a high pressure gas or liquid flow controller for liquid chromatography, chemical injection and sampling.

The LC223S provides constant flow with varying downstream pressure.



Contact Information:

Parker Hannifin Corporation
Veriflo Division
250 Canal Blvd
Richmond, California 94804

phone 510 235 9590
fax 510 232 7396
veriflo.sales@parker.com

www.parker.com/veriflo

Product Features:

- Repeatability: Flow is stable within $\pm 0.2\%$ of flow value under the following conditions:
 1. Ambient temperature varies no more than 10°F.
 2. Inlet pressure remains constant.
 3. Downstream pressure does not vary by more than 70% of established value.
- Wide Flow Range: From 25scc/m to 40 slpm.
- Wide Pressure Range: From 200 to 5000 psig (14 to 345 barg).
- Corrosion resistant.



ENGINEERING YOUR SUCCESS.

LC223S Flow Controller

Principle of Operation

The controller creates a constant differential pressure across a fixed area passage. Flow through the passage is proportional to the area of the passage and to the differential pressure across it. Since the differential pressure is kept constant, the flow is established by the sizing of the passage area.

Operation

The controller functions as a back pressure regulator which delivers a continuous flow. Its diaphragm assembly is subjected to two opposing forces. The force applied to the top of the diaphragm assembly is created by the dome pressure on the area of the diaphragm. The force applied to the bottom of the diaphragm assembly is the sum of the force created by the compression spring and the force created by the inlet pressure on the area of the diaphragm. The diaphragm assembly operates to control the opening of a nozzle in order to maintain a balance between the two opposing forces. If the force on top of the diaphragm assembly tends to exceed the force at the bottom, the imbalance will decrease the opening of the nozzle to increase the inlet pressure until the balance is restored. If the force on top of the diaphragm assembly tends to become smaller than the force at the bottom, the imbalance will increase the opening of the nozzle to reduce the inlet pressure until the balance is restored. Such an operation maintains a constant difference between the pressure in the dome and the pressure at the inlet. The magnitude of the difference is established by the compression spring. The dome of the controller is connected to the upstream side of the flow determining passage; the inlet is connected to the downstream side of the passage. In a typical application, the flow passage is capillary tubing (fixed orifice, or MFC). The differential pressure has a nominal value of 50 to 60 psi. For effective operation, it is required to have a minimum difference of 200 psi between the pressure upstream of the flow passage (applied to the dome) and the pressure at the outlet of the controller (connected to the process). If the application is concerned with gas flow, it is important to maintain the upstream pressure at a constant reference to prevent gas compressibility from affecting the stability of flow control.

EXAMPLE APPLICATION

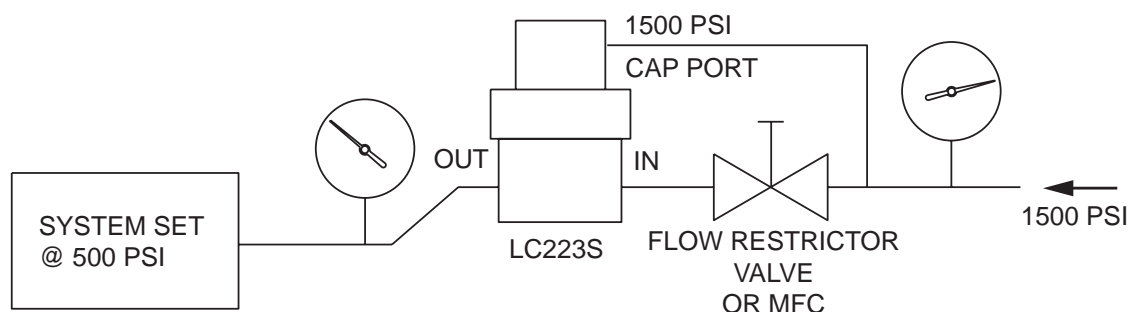

Safety Guide and Installation and Operating Instructions available at
www.parker.com/veriflo

LC223S Flow Controller

Dimensional Drawing

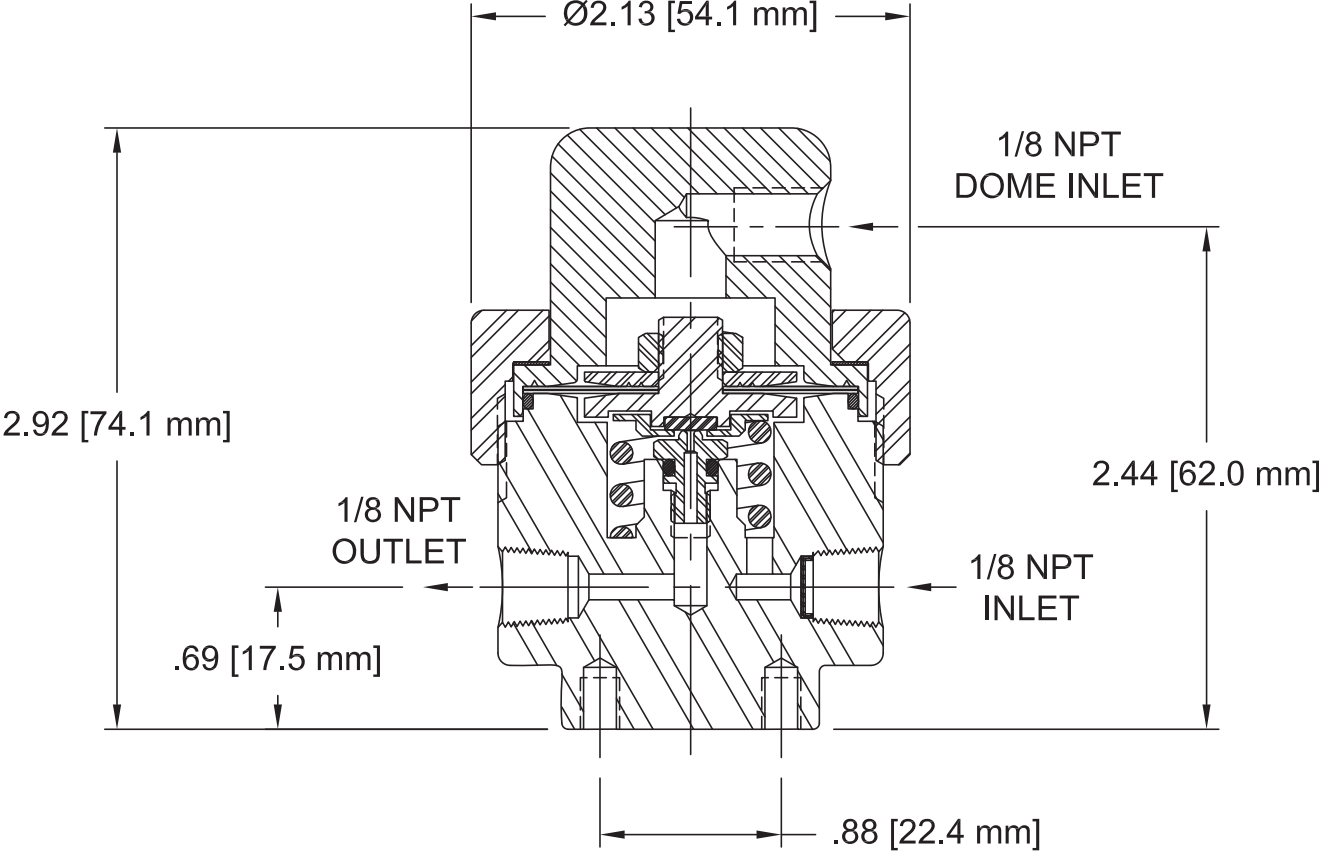

Ordering Information

LC223S Part Number54018192

LC223S Flow Controller

Specifications

Materials of Construction	
Wetted	
Body	316L Stainless Steel
Seal	Tefzel®
Diaphragm	316L Stainless Steel
Spring	17-7 PH
O-ring	FKM
Operating Conditions	
Maximum Inlet	5,000 psig (345 barg)
Maximum Dome Pressure	5,000 psig (345 barg)
Required Differential Pressure	200 psig (14 barg)
Temperature	-20°F to 150°F (-29°C to 66°C)

Tefzel® is a registered trademark of DuPont Performance Elastomers L.L.C.

Functional Performance	
Flow Range	25 sccm to 40 slpm <i>Established by Customer supplied flow restriction device</i>
Internal Volume	
Dome	2.0 cc
Body	2.1 cc

For additional information on materials of construction, functional performance and operating conditions, please contact factory.

OFFER OF SALE:

The items described in this document are hereby offered for sale by Parker-Hannifin Corporation, its subsidiaries or its authorized distributors. This offer and its acceptance are governed by the provisions stated in the detailed "Offer of Sale" elsewhere in this document or available at www.parker.com/veriflo

WARNING USER RESPONSIBILITY

FAILURE OR IMPROPER SELECTION OR IMPROPER USE OF THE PRODUCTS DESCRIBED HEREIN OR RELATED ITEMS CAN CAUSE DEATH, PERSONAL INJURY AND PROPERTY DAMAGE. THIS DOCUMENT IS FOR REFERENCE ONLY. PLEASE CONSULT FACTORY FOR LATEST PRODUCT DRAWINGS AND SPECIFICATIONS

This document and other information from Parker-Hannifin Corporation, its subsidiaries and authorized distributors provide product or system options for further investigation by users having technical expertise.

The user, through its own analysis and testing, is solely responsible for making the final selection of the system and components and assuring that all performance, endurance, maintenance, safety and warning requirements of the application are met. The user must analyze all aspects of the application, follow applicable industry standards, and follow the information concerning the product in the current product catalog and in any other materials provided from Parker or its subsidiaries or authorized distributors.

To the extent that Parker or its subsidiaries or authorized distributors provide component or system options based upon data or specifications provided by the user, the user is responsible for determining that such data and specifications are suitable and sufficient for all applications and reasonably foreseeable uses of the components or systems.