

P900 Series

Industrial Grade Glass Tube Flow Meter



Parker P Series glass tube flow meters deliver unsurpassed performance and value in a wide variety of gas and liquid flow applications.

P900 Series flow meters, available in 35 flow ranges from six tube sizes with full horizontal and vertical connection options, are the most versatile industrial glass tube meters available.

The powder coated 304 stainless steel case and precision molded polycarbonate shield will tolerate most corrosive applications, and the easily removable flow tube simplifies maintenance and replacement.

Designed, manufactured and tested in the US.



Contact Information:

Parker Hannifin Corporation
Porter Instrument Division
245 Township Line Road
Hatfield, PA 19440

phone 215 723 4000
fax 215 723 2199
Industrial@parker.com

www.parker.com/porter

Product Features and Options:

- Available in 35 flow ranges in six tube sizes
- NPT and flanged horizontal or vertical connections available
- Powder-coated 304 stainless steel case and clear polycarbonate front shield
- Industry standard dimensions
- Easily removable in-line glass tube
- Max temperature: 200°F (93°C) for both 316L SS and PVDF fittings
- Stable flow capacities up to 85 GPM water and 288 SCFM air
- Latching reed switch alarm option
- Certified calibrations conforming to ISA RP 16.6 available
- Detachable direct reading scales can be produced in any volumetric unit



ENGINEERING YOUR SUCCESS.

Specifications

Materials

Metering Tube	Borosilicate Glass
Internal Components	Standard 316L Stainless Steel Optional Hastelloy® C-276
Inlet/Outlet Fittings	FNPT or Flange, Vertical or Horizontal
Fitting Material	Standard 316L Stainless Steel Optional PVDF (FNPT Only)
Elastomers	Standard Viton® Optional Buna, EPR, and Kalrez®
Case	Powder-Coated 304 Stainless Steel
Cover	Molded Polycarbonate Shield

Hastelloy® is a registered trademark of Haynes International, Inc.
Viton® and Kalrez® are registered trademarks of DuPont Performance Elastomers L.L.C.

Options

Alarm	Latching Reed Switch
Valve	External Valve – 316L Stainless Steel (Size 3 to Size 6 FNPT only)
Certified Calibrations	Conform to ISA RP 16.6
Scales	Can be produced in any volumetric unit

Performance

Capacities	Water 0.27 to 85 GPM Air 1.15 to 288 SCFM
Scale	Sizes 3 to 6 250 mm (10") Sizes 8 to 9 200 mm (8") Direct reading, detachable (Dual scales available upon request)
Accuracy	±2% of Full Scale Flow
Turndown	10:1 unless otherwise indicated
Repeatability	1/2%
Maximum Temperatures	316L SS Fittings 200°F (93°C) PVDF Fittings 200°F (93°C)
Maximum Pressures	316L SS Fittings 300 psig, sizes 3 & 4 316L SS Fittings 250 psig, sizes 5 & 6 316L SS Fittings 150 psig, sizes 8 & 9 PVDF Fittings 150 psig, all sizes
Ambient Temperature	33°F to 125°F (1°C to 52°C)

Float Types

GS

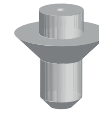

Semi Viscosity
Compensation

GV

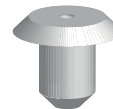

Maximum Viscosity
Compensation

LJ



Minimum Viscosity
Compensation

BL



No Viscosity
Compensation

⚠ WARNING – USER RESPONSIBILITY

FAILURE OR IMPROPER SELECTION OR IMPROPER USE OF THE PRODUCTS DESCRIBED HEREIN OR RELATED ITEMS CAN CAUSE DEATH, PERSONAL INJURY AND PROPERTY DAMAGE.

This document and other information from Parker-Hannifin Corporation, its subsidiaries and authorized distributors provide product or system options for further investigation by users having technical expertise.

The user, through its own analysis and testing, is solely responsible for making the final selection of the system and components and assuring that all performance, endurance, maintenance, safety and warning requirements of the application are met. The user must analyze all aspects of the application, follow applicable industry standards, and follow the information concerning the product in the current product catalog and in any other materials provided from Parker or its subsidiaries or authorized distributors.

To the extent that Parker or its subsidiaries or authorized distributors provide component or system options based upon data or specifications provided by the user, the user is responsible for determining that such data and specifications are suitable and sufficient for all applications and reasonably foreseeable uses of the components or systems.

Offer of Sale

The items described in this document are hereby offered for sale by Parker-Hannifin Corporation, its subsidiaries or its authorized distributors. This offer and its acceptance are governed by the provisions stated in the detailed "Offer of Sale" elsewhere in this document or available at www.parker.com/offerofsale.

Flow Ranges and Dimensions

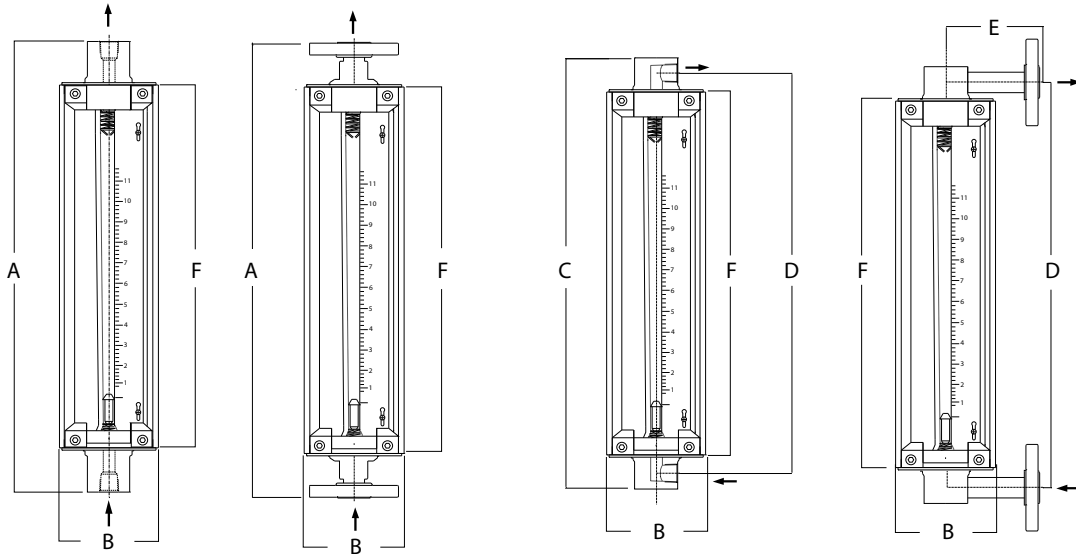

Order #	Full Scale Flow GPM – Water	Order #	Full Scale Flow SCFM – Air	Float #	Float Type	Alarm Option	Press. Drop in WC	Dimensions (Inches)						Connection Size (Inches)	
								A	B	C	D	E	F	FNPT	Flange
31W	0.27	31A	1.15	3-BLG-01	BL	No	4	19.7	4.13	18.86	17.5	3.94	16.1	1/2	1/2
32W	0.49	32A	2.1	3-BLG-02	BL	No	4	19.7	4.13	18.86	17.5	3.94	16.1	1/2	1/2
33W	0.64	33A	2.64	3-HFG-01	HF	Yes	4	19.7	4.13	18.86	17.5	3.94	16.1	1/2	1/2
34W	0.77	34A	3.2	3-LJG-01	LJ	Yes	4	19.7	4.13	18.86	17.5	3.94	16.1	1/2	1/2
41W	1.1	41A	4.2	4-GVG-01	GV	Yes	6	19.7	4.13	18.86	17.5	3.94	16.1	1/2	1/2
42W	1.3	42A	5.5	4-GSG-01	GS	Yes	6	19.7	4.13	18.86	17.5	3.94	16.1	1/2	1/2
43W	1.5	43A	6.2	4-GVG-02	GV	Yes	8	19.7	4.13	18.86	17.5	3.94	16.1	1/2	1/2
44W	1.8	44A	7.6	4-GSG-02	GS	Yes	9	19.7	4.13	18.86	17.5	3.94	16.1	1/2	1/2
45W	2.2	45A	9	4-GSG-03	GS	Yes	15	19.7	4.13	18.86	17.5	3.94	16.1	1/2	1/2
46W	2.5	46A	10.2	4-GSG-03	GS	Yes	19	19.7	4.13	18.86	17.5	3.94	16.1	1/2	1/2
47W	3.4	47A	14	4-GSG-04	GS	Yes	27	19.7	4.13	18.86	17.5	3.94	16.1	1/2	1/2
51W	2.5	51A	10	5-GVG-01	GV	Yes	6	19.7	4.13	18.86	17.5	4.72	16.1	3/4	1
52W	3	52A	12	5-GSG-01	GS	Yes	6	19.7	4.13	18.86	17.5	4.72	16.1	3/4	1
53W	3.5	53A	14.4	5-GSG-02	GS	Yes	10	19.7	4.13	18.86	17.5	4.72	16.1	3/4	1
54W	4	54A	16.4	5-GVG-02	GV	Yes	15	19.7	4.13	18.86	17.5	4.72	16.1	3/4	1
55W	5	55A	20	5-LJG-01	LJ	Yes	41	19.7	4.13	18.86	17.5	4.72	16.1	3/4	1
61W	6.5	61A	26.8	6-GSG-01	GS	Yes	13	19.7	4.13	18.86	17.5	4.72	16.1	3/4	1
62W	7	62A	28.8	6-GVG-01	GV	Yes	20	19.7	4.13	18.86	17.5	4.72	16.1	3/4	1
63W	8.2	63A	34	6-GSG-02	GS	Yes	27	19.7	4.13	18.86	17.5	4.72	16.1	3/4	1
64W	10.5	64A	44	6-GVG-02	GV	Yes	30	19.7	4.13	18.86	17.5	4.72	16.1	3/4	1
65W	13	65A	54	6-GSG-03	GS	Yes	32	19.7	4.13	18.86	17.5	4.72	16.1	3/4	1
66W	16	66A	66	6-GVG-03	GV	Yes	48	19.7	4.13	18.86	17.5	4.72	16.1	3/4	1
67W	20	67A	82	6-HFG-01	HF	Yes	97	19.7	4.13	18.86	17.5	4.72	16.1	3/4	1
81W	15	81A	61	8-GVG-01	GV	Yes	8	19.7	5.75	23.26	20.5	5.12	16.3	1 1/2	1 1/2
82W	20	82A	82	8-GVG-02	GV	Yes	13	19.7	5.75	23.26	20.5	5.12	16.3	1 1/2	1 1/2
83W	25	83A	103	8-GVG-03	GV	Yes	22	19.7	5.75	23.26	20.5	5.12	16.3	1 1/2	1 1/2
84W	28	84A	122	8-GSG-01	GS	Yes	30	19.7	5.75	23.26	20.5	5.12	16.3	1 1/2	1 1/2
85W	32	85A	145	8-GSG-02	GS	Yes	24	19.7	5.75	23.26	20.5	5.12	16.3	1 1/2	1 1/2
86W	36	86A	155	8-HFG-01	HF	Yes	43	19.7	5.75	23.26	20.5	5.12	16.3	1 1/2	1 1/2
91W	41	91A	165	9-GVG-01	GV	Yes	28	19.7	5.75	23.26	20.5	5.12	16.3	1 1/2	1 1/2
92W	50	92A	195	9-GVG-02	GV	Yes	44	19.7	5.75	23.26	20.5	5.12	16.3	1 1/2	1 1/2
93W	60	93A	245	9-GSG-01	GS	Yes	36	19.7	5.75	23.26	20.5	5.12	16.3	1 1/2	1 1/2
94W	70	94A	285	9-HFG-01	HF	Yes	62	19.7	5.75	23.26	20.5	5.12	16.3	1 1/2	1 1/2
95W	85	-	-	9-LJG-01	LJ	Yes	88	19.7	5.75	23.26	20.5	5.12	16.3	1 1/2	1 1/2

Ordering Information

Use the following guide to determine the specific product number you require.

The following example describes a P900 flow meter with 3/4" 316L SS vertical FNPT flange, 316L SS float material, EPR O-ring and no alarm.

Example:
P90012155W0

Gases equivalent to Air @ 21.1°C 1 atmos (Standard)

Liquid equivalent to water density 1.0 g/cm³, viscosity 1.0cp

Hastelloy® is a registered trademark of Haynes International, Inc.
Viton® and Kalrez® are registered trademarks of DuPont Performance Elastomers L.L.C.

Model Number, Example & Options					Description
P900	1	2	1	55W	0
Fitting Material	1				Vertical FNPT - 316L SS - Order Number 31A - 47W
					Vertical FNPT - 316L SS - Order Number 51A - 67W
					Vertical FNPT - 316L SS - Order Number 81A - 86W
					Vertical FNPT - 316L SS - Order Number 91A - 95W
	2				Horizontal FNPT - 316L SS - Order Number 31A - 47W
					Horizontal FNPT - 316L SS - Order Number 51A - 67W
					Horizontal FNPT - 316L SS - Order Number 81A - 86W
					Horizontal FNPT - 316L SS - Order Number 91A - 95W
	3				Vertical 150# Flange - 316L SS - Order Number 31A - 47W
					Vertical 150# Flange - 316L SS - Order Number 51A - 67W
					Vertical 150# Flange - 316L SS - Order Number 81A - 86W
					Vertical 150# Flange - 316L SS - Order Number 91A - 95W
	4				Vertical 300# Flange - 316L SS - Order Number 31A - 47W
					Vertical 300# Flange - 316L SS - Order Number 51A - 67W
					Vertical 300# Flange - 316L SS - Order Number 81A - 86W
					Vertical 300# Flange - 316L SS - Order Number 91A - 95W
	5				Horizontal 150# Flange - 316L SS - Order Number 31A - 47W
					Horizontal 150# Flange - 316L SS - Order Number 51A - 67W
					Horizontal 150# Flange - 316L SS - Order Number 81A - 86W
					Horizontal 150# Flange - 316L SS - Order Number 91A - 95W
	6				Horizontal 300# Flange - 316L SS - Order Number 31A - 47W
					Horizontal 300# Flange - 316L SS - Order Number 51A - 67W
					Horizontal 300# Flange - 316L SS - Order Number 81A - 86W
					Horizontal 300# Flange - 316L SS - Order Number 91A - 95W
	7				Vertical FNPT - PVDF - Order Number 31A - 47W
					Vertical FNPT - PVDF - Order Number 51A - 67W
					Vertical FNPT - PVDF - Order Number 81A - 86W
					Vertical FNPT - PVDF - Order Number 91A - 95W
	8				Horizontal FNPT - PVDF - Order Number 31A - 47W
					Horizontal FNPT - PVDF - Order Number 51A - 67W
					Horizontal FNPT - PVDF - Order Number 81A - 86W
					Horizontal FNPT - PVDF - Order Number 91A - 95W
Float Material	2				316L SS
	4				Hastelloy C-276® - Order Number 31A - 47W
					Hastelloy C-276® - Order Number 51A - 67W
					Hastelloy C-276® - Order Number 81A - 86W
				Hastelloy C-276® - Order Number 91A - 95W	
O-ring Material	1				Ethylene Propylene Rubber (EPR)
					Nitrile Rubber (NBR)
					Fluorinated Propylene Monomer (FPM/FKM)
	4				Kalrez® - Order Number 31A - 47W
					Kalrez® - Order Number 51A - 67W
					Kalrez® - Order Number 81A - 86W
					Kalrez® - Order Number 91A - 95W
	Order Number			55W	
Alarm Option				0	Without Alarm
				1	With Alarm